



## **V50 Series Electrical Safety Testers**



### **Operating Manual** Models V50, V51, V52 and V53

## WARNING

Vitrek Corporation, its representatives, vendors and distributors assume no liability for the operation of this instrument an unsafe manner. This instrument generates and delivers hazardous voltages (up to 5KVAC / 6KVDC). Always be extremely careful when using this instrument or any high voltage device. Read the manual completely and observe operating precautions in section 3 before operating the instrument.

### Technical Support

After reading this manual, should you have any questions or need technical assistance – please contact Vitrek customer support at:

Email: [info@vitrek.com](mailto:info@vitrek.com)

Fax: 858-558-9688

Voice: 858-558-4530 ext. 201

Vitrek Corporation

9955 Mesa Rim Road

San Diego, CA 92121 USA

### Limited Warranty

The standard warranty period for this instrument is one year from date of shipment. Please refer to your invoice or shipping documents to determine appropriate warranty dates. Vitrek warrants to the original purchaser that this product will be free from defects in material and workmanship under normal use throughout the warranty period, provided that such defects are not determined by Vitrek to have been caused by abuse, misuse, alteration, improper installation, neglect or adverse environmental conditions. Vitrek Corporation's liability under this warranty is limited solely to the repair or replacement of this instrument during the warranty period, provided it is returned to the factory freight prepaid with a return authorization number.

No other warranty is expressed or implied. Vitrek Corporation is not liable for incidental, consequential, direct or indirect damages nor for costs, losses or expenses of any kind. A return authorization number must be obtained directly from the factory for warranty repairs. No liability will be accepted if returned without factory authorization number.

### Extended Three Year Warranty Program

To qualify your instrument for an extended three year warranty period you must:

1. Register your unit within 30 days from receipt by faxing or emailing the following data

Vitrek Model no. & S/N	
Contact Name	
Company / Organization	
Street Address	
City, State, Zip Code	
Contact Email Address	
Contact Phone Number	

2. Contact the factory for a reference number to return your unit to the factory for annual calibration and re-certification prior to the expiration of the initial cal due date. Upon receipt of your PO for the calibration fee, the warranty will be extended for an additional year (up to a maximum of three years total warranty).

## Vitrek V50 Series – Electrical Safety Tester USER MANUAL

---

TABLE OF CONTENTS	PAGE
1. INTRODUCTION to V50 SERIES.....	3
1-1.Description.....	3
1-2.Features.....	3
2. SPECIFICATIONS.....	4
3. PRECAUTIONS BEFORE OPERATION.....	5
3-1.Unpacking the instrument.....	5
3-2.Safety notice.....	5
3-3.Environment.....	6
4. PANEL INTRODUCTION.....	7
4-1.Front Panel.....	7
4-2.Rear Panel.....	8
5. OPERATING METHOD.....	9
5-1.Main LCD Display.....	9
5-2.Preparing the EST for Use .....	10
5-3.Structure of stored test steps.....	16
5-4.Menu parameter setup & Operation .....	16
5-5.Remote Interface Operation.....	19
6. MAINTENANCE.....	20
6-1.Fuse rating and type.....	20
6-2.Cleaning.....	20

### SAFETY TERMS AND SYMBOLS

These terms may appear in this manual or on the product:



**WARNING.** Warning statements identify conditions or practices that could result in injury or loss of life.



**CAUTION.** Caution statements identify conditions or practices that could result in damage to this product or other property.

The following symbols may appear in this manual or on the product:



**DANGER**  
High Voltage



**ATTENTION**  
Refer to Manual



**Protective**  
Conductor  
Terminal



**Ground**  
Terminal

## **Vitrek V50 Series – Electrical Safety Tester USER MANUAL**

---

### **1. V50 SERIES PRODUCT INTRODUCTION**

Our goal at Vitrek is 100% customer satisfaction with both our products and our people. Please feel free to contact us if we can be of help with application or technical assistance, repair or calibration services accessories or spare parts.

Vitrek Corporation  
9955 Mesa Rim Road  
San Diego, CA 92121

Phone 858.558.4530 Fax 858.558.9688 email [info@vitrek.com](mailto:info@vitrek.com)

#### **1-1. Description**

The Vitrek V50 Series Electrical Safety Testers comply with the requirement for electrical equipment & appliance control ordinances as defined by UL, CSA, JIS, BS and many other international standards. The testers are ideal for voltage withstand (Hipot) testing on a wide variety of electrical equipment and components. The Vitrek V50 series is a family of four automatic voltage withstand testers. The functions they provide include AC Hipot, DC Hipot, Insulation Resistance plus continuity.

Function Model	AC	DC	IR
V50	X		
V51	X	X	
V52	X		X
V53	X	X	X

#### **1-2. Features**

The V50 series electrical safety testers offer many outstanding features:

- 1) **No load setup of trip current and output voltage.** A safe way to setup the trip current and output voltage without the high voltage being activated.
- 2) **A large 24×2 character LCD with adjustable LED backlight.**  
Provides a clear display, which shows test parameters, including group, step, mode, status, output voltage, trip current and test time.
- 3) **Easy and quick setup via the front panel.** A user-friendly interface provides user with an easy and quick way to set all parameters.
- 4) **Electronic ramping and testing.** Digital controlled ramping time and testing time.
- 5) **Line and load regulation.** Linear amplifier with feedback-control, maintains output voltage regardless of the variation of load.
- 6) **Selectable output frequency.** 50/60 Hz is selectable by utility setup.
- 7) **Adjustable ARC detect level.** ARC detect level is selected by utility setup.
- 8) **Storage of up to 6 groups, 6 steps for each group.** A total of 6 groups provides the operator with the capability of testing different products. Each group includes 6 steps.
- 9) **Manual output voltage adjustment mode.** With a special test mode in step 0, the operator is able to adjust the output voltage during testing.
- 10) **Flashing high voltage indicator.** A flashing red LED indicates danger when high voltage output is activated.
- 11) **PLC remote control.** The 9-pin interface provides inputs ( START, RESET ) and outputs ( TEST, PASS, FAIL ).
- 12) **Data lock function.** Front panel can be locked or unlocked by utility setup.
- 13) **Ground Check function.** Check the continuity of earth ground in the power inlet before testing.

**Vitrek V50 Series – Electrical Safety Tester USER MANUAL**

---

**V50 SERIES SPECIFICATIONS****AC Hipot**

**Voltage Range:** 100 to 5000 VAC RMS  
**Voltage Setting Resolution:** 5V/step  
**Voltage Regulation:** 1% of reading + 5V  
**Voltage Accuracy:** 1% of reading + 5V  
**Voltage Monitoring:** At Output Terminals  
**Max Output Current:** 20mA\*  
**Min/Max Current Limits:** 0.01 to 20mA  
**Current Accuracy:** 1% of reading + 0.05mA

**DC Hipot (V51, V53 only)**

**Voltage Range:** 100 to 6000 VDC  
**Voltage Setting:** Resolution: 5V/step  
**Voltage Regulation:** 1% of reading + 5V  
**Voltage Accuracy:** 1% of reading + 5V  
**Voltage Monitoring:** At Output Terminals  
**Max Output Current:** 7.5mA  
**Min/Max Current Limits:** 0.01 to 20mA  
**Current Accuracy:** 1% of reading + 0.05mA

**Insulation Resistance (V52, V53 only)**

**DC Output Voltage:** 500V or 1000V  
**Resistance Range:** 1 to 9999M $\Omega$   
**Resistance Accuracy:** 1 to 500M $\Omega$  5% of reading, 501 to 2000M $\Omega$  10% of reading

**Continuity Measurement**

**Test Current:** 100mA  $\pm$  10mA  
**Resistance Range:** .001 to 1.500 $\Omega$   
**Resistance Accuracy:** 0.1 $\Omega$

**General**

**Test Database:** 6 Test Sequences with up to 6 steps per test sequence  
**Front Panel Lockout:** Prevents database edit while in lockout mode  
**Arc Detect:** 10 level trip select  
**Remote Interface:** 9-pin D-sub connector with Outputs of Testing, Pass, Fail and inputs of Start, Reset.  
Output isolation is 400V with 130mA Continuous load current.  
**Timer Accuracy:** 0.10%  $\pm$  50mS  
**Power Source:** AC100V, 120V, 220V,  
230V ( $\pm$ 10% 50/60Hz), 250W max  
**Operating Environment:** Indoor use, Altitude up to 6500ft (2000m). Installation Category II. Pollution Degree 2  
**Operating Temperature:** 0°C to 40°C, 80% RH max.  
**Storage Temperature:** -10°C to 70°C, 70% RH max

## **Vitretek V50 Series – Electrical Safety Tester USER MANUAL**

---

**Dimension:** 17.6”L x 13”W x 5.9”H, 446(L) x 330(W) x 149(H)mm

**Weight:** 30 lbs (14kg) net, 34 lbs (16 kg) ship

**Accessories:** NIST certification, TL-2050 Test Leads, Instruction Manual and power cord

**Accuracy:** Stated specifications apply for 1 year at 23 °C ± 5 °C

**Calibration:** Certificate of calibration, traceable to NIST provided

**Compliance:** CE mark certified to EN61010 and EMC directives EN50081-1 & EN50082-2

**QuickTest™ Software Option QT-50:** Bundled test automation software, with PC parallel interface adapter and cable. Easy to load Graphical test sequence development and operating environment. Provides time/date, operator, test parameters, and test results for review, printout or export to database program.

### **3. PRECAUTIONS BEFORE OPERATION**

#### **3-1. Unpacking the instrument**

The product has been fully inspected and tested before shipping from the factory. Upon receiving the instrument, please unpack and inspect it for any damage that may have occurred during transportation. If any sign of damage is found, notify the carrier and Vitrek or your distributor immediately.

#### **3-2. Safety Notice**

##### **Work Place Safety**

The work place must be isolated from routine traffic and when high voltage testing is in process, a warning signal should be provided.

##### **Checking the Line Voltage**

The instrument can be connected to any kind of line voltage shown in the table below. Before connecting the power plug to an AC line outlet, make sure the voltage selector on the rear panel is set to the correct position corresponding to the line voltage. **CAUTION:** Damage to the instrument may occur if it is connected to the wrong AC line voltage.



**WARNING.** To avoid electrical shock the power cord protective grounding conductor must be connected to ground.

## **Vitretek V50 Series – Electrical Safety Tester USER MANUAL**

---

When line voltage is changed, install the required fuses shown as below:

Line voltage	Range	Fuse	Line voltage	Range	Fuse
100V	90-110V	T 4.0A	220V	198-242V	T 4.0A
120V	108-132V	250V	230V	207-250V	250V



**WARNING.** To avoid personal injury, disconnect the power cord before removing the fuse holder.

### **Operator's Precaution**

- (1) Because of the extreme high output voltage and current of the breakdown tester, only a qualified person should operate the tester in order to avoid fatal electric shock.
- (2) On-the-job training is required for the operator to use the tester efficiently and safely.
- (3) The operator should be prohibited from wearing metal jewelry, etc in order to avoid an electrical shock.
- (4) A person with a heart condition or who wears a pacemaker must not operate the tester.

### **Safe, Secure Testing**

The earth ground contact of the power cord must be properly connected in accordance with instructions. The return lead must be connected to the tested object first before high voltage testing. Do not handle the alligator test leads while high voltage is applied. Also, when using the optional HV probe do not touch the exposed conductive tip of the test probe during testing. Provide full control the power supplied to the tester by means of a carefully placed on/off switch or remote power control device.



**WARNING:** During testing, do not touch the test object or any other connected objects.

### **3-3.Environment**

The normal ambient temperature range of this instrument is from 0° to 40°C (32° to 104°F). Operation of the instrument above this specific temperature range may cause damage to the circuits.

Do not use the instrument in a place where a strong magnetic or electric field exists, as they may distort the measurements.

# Vitrek V50 Series – Electrical Safety Tester USER MANUAL

## 4. PANEL INTRODUCTION

### ● Front Panel

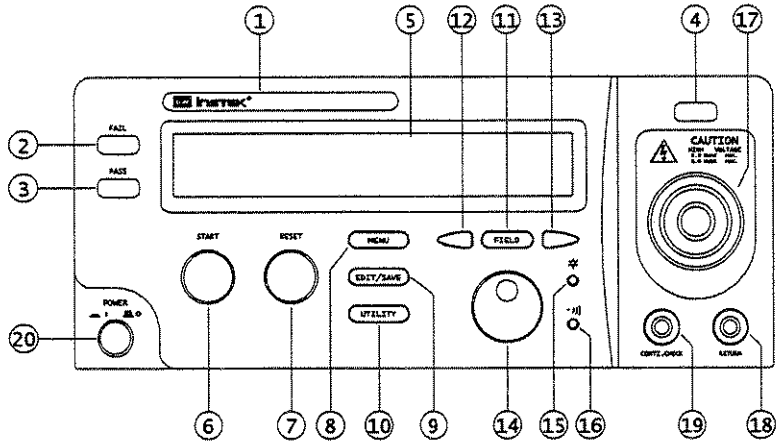

### ● Rear Panel

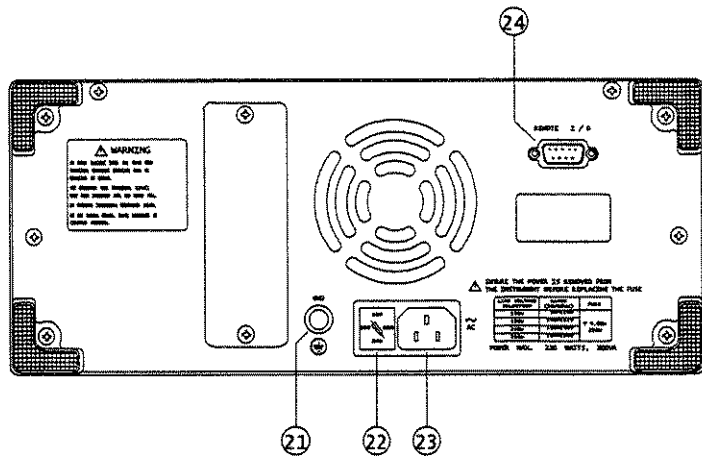



## Vitrek V50 Series – Electrical Safety Tester USER MANUAL

---

1	Model Number	Model number and description
2	FAIL Indicator LED	The red LED indicates failure of test procedure
3	PASS Indicator LED	The green LED indicates pass of test procedure
4	CAUTION Indicator LED	During test the red LED will flash to indicate danger.
5	Main Display LCD	The LCD displays all message about test procedure
6	START Button	Press the green button to start a test procedure
7	RESET Button	Press the red button to reset/stop a test procedure
8	MENU Key	When you press the MENU key, the status becomes MENU and you can browse all groups.
9	EDIT/SAVE Key	When you press the EDIT/SAVE key, the status EDIT is active and you can edit this step or setup. Press the EDIT/SAVE key again will save this step or setup.
10	UTILITY Key	When you press the UTILITY key, the status UTILITY is active and you can view all the utility setups.
11	FIELD Key	When you edit the test step, press the FIELD key to change the active parameter of stop.
12	Left Arrow Key	Press the arrow key to adjust knob's resolution.
13	Right Arrow Key	Press the arrow key to adjust knob's resolution.
14	Knob	If status EDIT is active, turn the knob to increase or decrease the value of active parameter. If status MENU is active, turn the knob to increase or decrease active Step.

15	LCD Backlight Adjustment	Turn the VR to adjust the LED backlight of LCD.
16	Buzzer Volume Adjustment	Turn the VR to adjust the buzzer volume.
17	High Voltage Output Seat	High voltage output terminal.
18	RETURN Terminal	Test return terminal.
19	CONTI. CHECK Terminal	Continuity check output terminal.
20	Power Switch	Press the power switch to turn on the tester.
21	Ground Terminal	Connect Ground terminal to the earth ground.
22	Fuse Holder with Voltage Selector	To change AC source voltage, pull the fuse holder and rotate it to the proper value.
23	AC Inlet	Connect the AC power line to the inlet.
24	Remote I/O	The remote I/O performs all the functions of PLC control.

**5. OPERATING THE INSTRUMENT**

**5-1. Main Display LCD**

Storage	Mode	Output Voltage/Current	Status
1 : 1	ACW	V = 5 . 0 0 0 k V	RE A D Y
I m A x = 0 1 . 0 0 m A		T E S T = 0 0 0 . 0 s	
Measurement Limit		Ramp/Test Time	

**Table of parameters**

Storage	Group: Step There are a of total 6 groups, 6 steps for each group. The first number indicates group while the second number indicates step. Ex. 3:1 means the 1st Step in group 3 is active.
Mode	The test mode of tester includes: ACW: AC Withstanding voltage test DCW: DC Withstanding voltage test I R : Insulation Resistance test Cont: Continuity check The available modes vary by model.

Output Voltage/Current	Output voltage or current for each step A C : Output voltage (0.100~ 5.000 kV) D C : Output voltage (0.100~ 6.000 kV) I R : Output voltage (0.500kV or 1.000kV) Cont: Output current (0.100A)
Status	The status of tester includes: MENU: Browse and check steps of test. E D I T : Edit parameters S A V E : Save parameters U T I L : Browse and check system utility. R E A D Y : Ready for test T E S T : Testing P A S S : The result of test is pass F A I L : The result of test is fail S T O P : Stop the test
Measurement Limit	Lower and upper limit of measurement I m a x / I m i n : Current measurement limit (ACW & DCW) R m a x / R m i n : Resistance measurement limit (IR & Cont)
Ramp/Test Time	Ramp time and test time A C : Ramp/Test (000.0~999.9 s) D C : Ramp/Test (000.0~999.9 s) I R : Test (000.0~999.9 s) Con: Test (000.0~999.9 s)

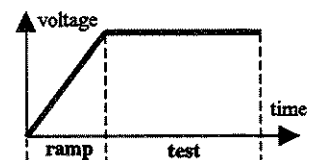

## Vitrek V50 Series – Electrical Safety Tester USER MANUAL

### 5-2. Preparing the V50 Series EST for Use

- To view the Stored Steps

1. Press the **MENU** key to access test number field.

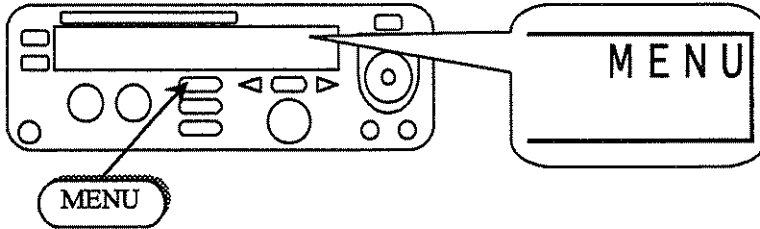

2. Use the left and right arrow keys to select group or step. Use the knob to change the active step.

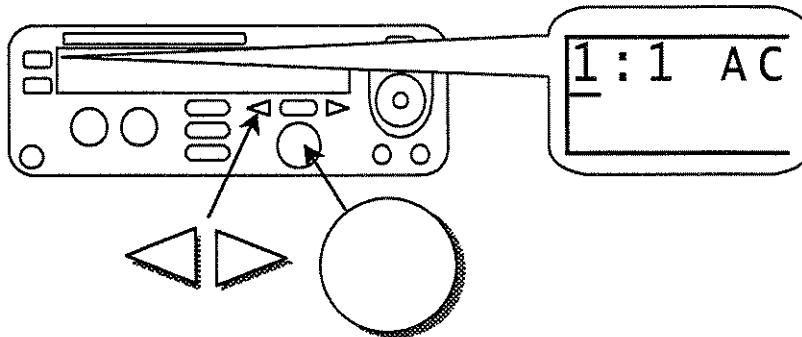

#### To Edit and Save the Stored Steps

1. Follow the above procedure "To View the Stored Steps" in order to select the desired step.
2. Press the **EDIT/SAVE** key to enter EDIT status.

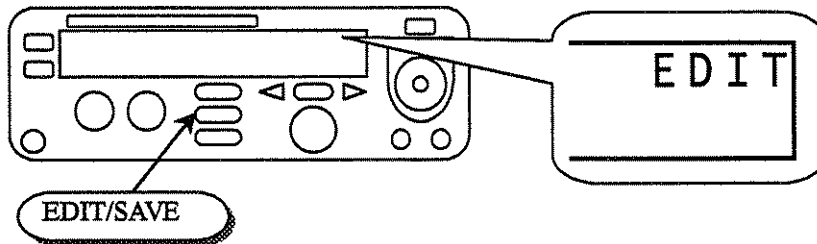

## Vitretek V50 Series – Electrical Safety Tester USER MANUAL

3. Use the knob to adjust the parameter. Use arrow keys to change the knob's resolution.

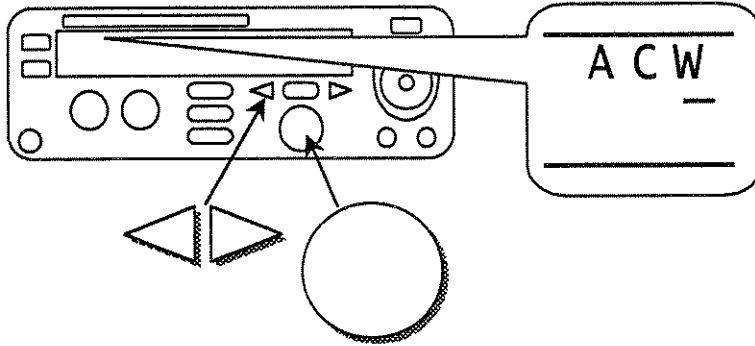

4. Use **FIELD** key to advance to the next parameter field.

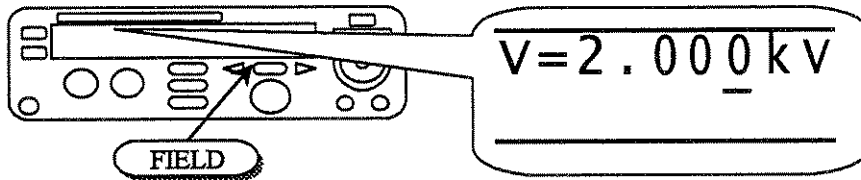

5. Repeat step 3 and 4 to adjust parameter.

6. After setting all parameters, press **EDIT/SAVE** key to save the step. The status will become SAVE. After the step is saved, the status will return to EDIT.

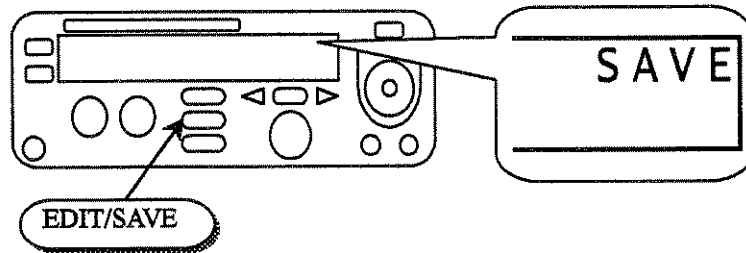

7. Repeat the procedure "To View the Stored Steps" to select another step.

## Vitrek V50 Series – Electrical Safety Tester USER MANUAL

- **To Begin a Group Test**

1. Repeat the procedure “To View the Stored Steps” to select a step.
2. Press RESET button to enter status READY.

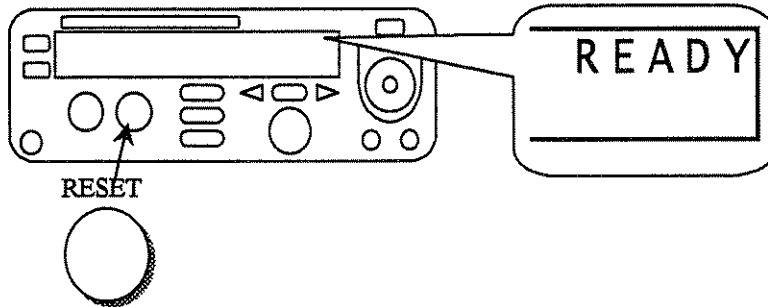

3. Make sure the test environment is safe.
4. Press START button to start the test while the status TEST is active and the CAUTION LED flashes.

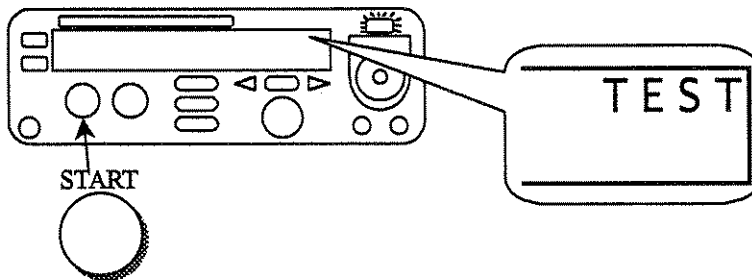

5. If you press RESET button the test will stop immediately.

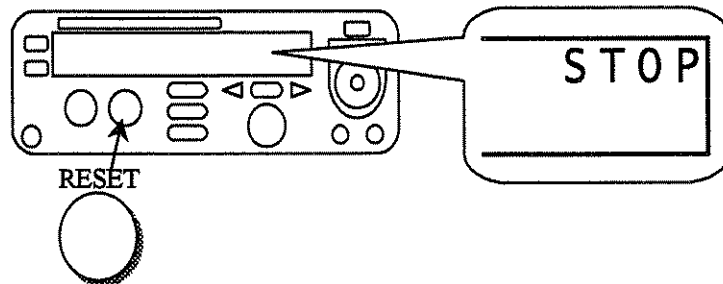

6. If the result is pass, the PASS LED will be active.

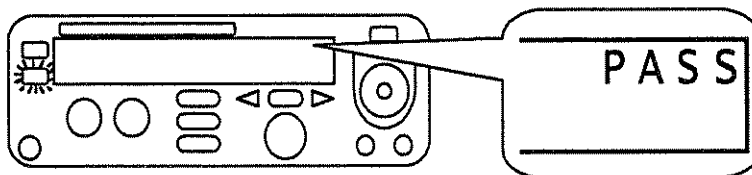

## Vitrek V50 Series – Electrical Safety Tester USER MANUAL

7. If the result is fail, the FAIL LED will be active and the buzzer will alarm the operator. To stop the alarm, press RESET button again.

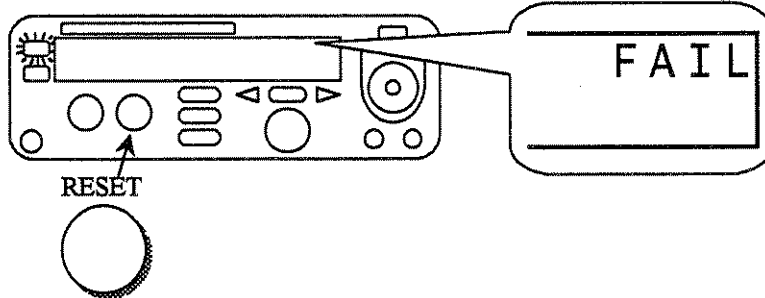

8. Use the knob to view the result of group step by step.

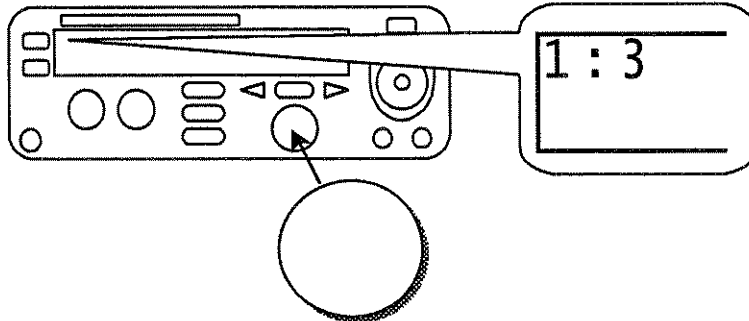

- To View the System Utility

1. Press the **UTILITY** key to enter status UTIL.

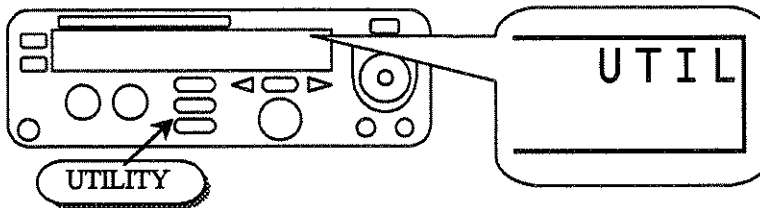

2. Use the knob or arrow keys to change the active parameter.

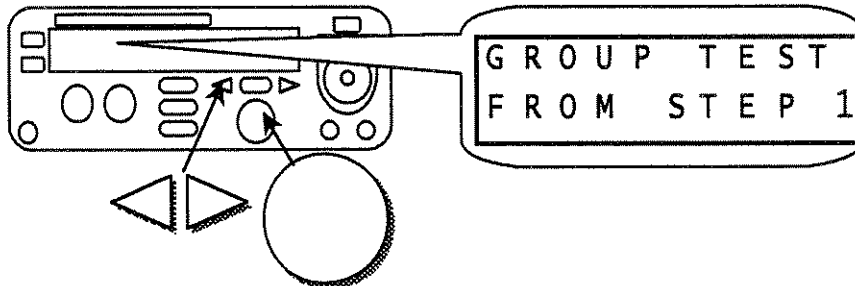

## Vitretek V50 Series – Electrical Safety Tester USER MANUAL

---

### 3. Table of system utility:

Parameter	Option	Description
<b>GROUP TEST</b>	From STEP 1	The group test procedure always begins from step 1 to end of group. e.g. 3:1~3:6, 4:1~4:6
	From the present step	The group test procedure always begins from the step selected to end of group. e.g. 3:3~3:6, 4:3~4:6
<b>ARC MODE</b>	DISABLE	Disable the function arc detection.
	ENABLE & STOP	Enable the arc detection and stop the test when arc is active.
	ENABLE & CONTINUE	Enable the arc detection and continue the test when arc is active.
<b>ARC CURRENT</b>		Set the current level of arc detection.
<b>AC FREQUENCY</b>	50 Hz	Set the ac hipot output frequency to 50 Hz.
	60 Hz	Set the ac hipot output frequency to 60 Hz.
<b>EARTH CHECK</b>	ENABLE	The function EARTH CHECK will check the continuity of earth ground in power inlet. The EST will stop if the check is fail.
	DISABLE	Disable this check will cause the EST work without check the continuity of earth ground. It will be dangerous for operator.
<b>PLC CONTROL MODE</b>	MODE 1	Control mode of 9-pin remote I/O. Mode 1: Double click
	MODE 2	Mode 2: Press start button directly.
	MODE 3	Mode 3: Reserved.
<b>DATA LOCK</b>	UNLOCKED	Accepts and saves all parameters of test step and utility.
	LOCKED	Will not change any parameters of test step and utility.
<b>Conti. Calibration</b>		Calibrates (zeroes) the resistance of test leads for the Continuity check.

## Vitrek V50 Series – Electrical Safety Tester USER MANUAL

### ● To Edit/Save the System Utility

1. Follow the above procedure “To View the System Utility “ to select a parameter.
2. Press the **EDIT/SAVE** key to enter status EDIT.

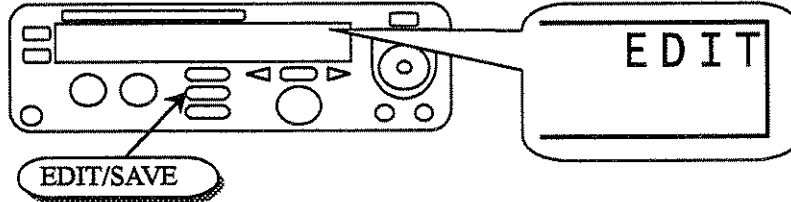

3. Use the knob to adjust the parameter. Use arrow keys to change the knob's resolution.

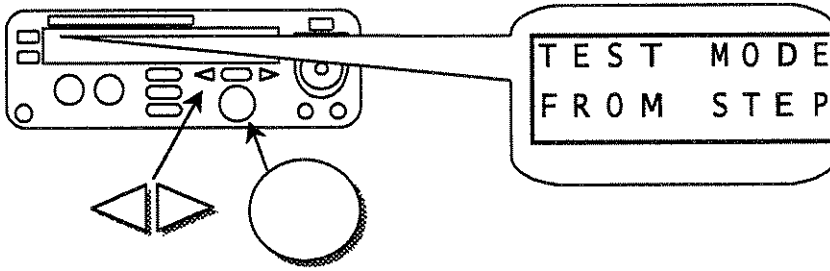

4. After setting the parameter, press **EDIT/SAVE** key in order to save the parameter. The status will become SAVE. After the parameter is saved, the status will return to EDIT.

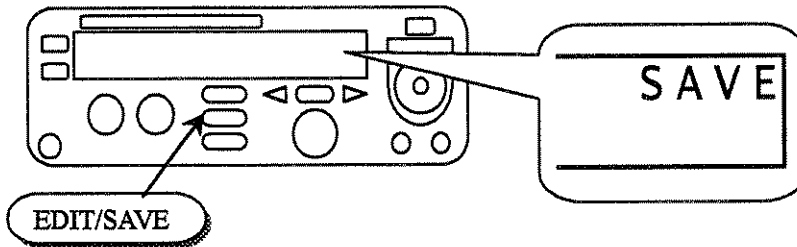

5. Repeat the procedure “To View the System Utility” to select another parameter.



## Vitrek V50 Series – Electrical Safety Tester USER MANUAL

### 5-3. Structure of Test Sequence Storage

The test sequence database of the EST consists of a total of 6 test sequences or groups (group 1 ~ group 6), with 6 steps (step 1 ~ step 6) for each group. In addition to these steps, there is another step "0:0" for manually controlled tests. The order of stored steps is Group: Step. The first number represents the Group number while the second represents the Step number.

		Group 1	Group 2	Group 3	Group 4	Group 5	Group 6
Step 1	0:0 →	1:1 →	2:1 →	3:1 →	4:1 →	5:1 →	6:1
		↓	↓	↓	↓	↓	↓
Step 2		1:2	2:2	3:2	4:2	5:2	6:2
		↓	↓	↓	↓	↓	↓
Step 3		1:3	2:3	3:3	4:3	5:3	6:3
		↓	↓	↓	↓	↓	↓
Step 4		1:4	2:4	3:4	4:4	5:4	6:4
		↓	↓	↓	↓	↓	↓
Step 5		1:5	2:5	3:5	4:5	5:5	6:5
		↓	↓	↓	↓	↓	↓
Step 6		1:6	2:6	3:6	4:6	5:6	6:6

The special test step "0:0" contains another two types of tests: CAC and CDC. The function of CAC and CDC is the same as ACW and DCW, except that the user is able to manually adjust the output voltage with the knob during the test.

### 5-4. Menu parameter setup

- **AC/DC Hipot - Voltage withstand test (ACW/DCW)**

Press MENU key to enter MENU mode then use knob and arrow keys to select a step.

Press EDIT/SAVE key to enter EDIT mode. The cursor stays at the "test mode" field. Use knob to select desired test ACW (DCW).

Functionality of FIELD key:

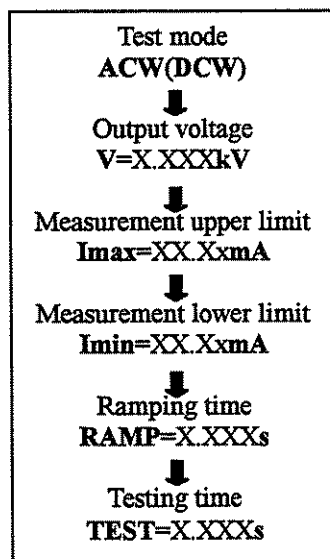

## Vitrek V50 Series – Electrical Safety Tester USER MANUAL

Press FIELD key to edit the next field “output voltage”. Use the knob to adjust the desired output voltage while using the arrow keys to adjust the knob’s resolution (0.100~ 5.000 kV for ACW, 0.100~ 6.000 kV for DCW).

Press FIELD key again to enter the next field “measurement upper limit”. Use the knob to adjust the desired upper limit of leakage current while using the arrow keys to adjust the knob’s resolution (0.10~15mA for ACW, 0.10~7.5mA for DCW).

Press FIELD key again to enter the next field “measurement lower limit”. Use the knob to adjust the desired lower limit of leakage current while using the arrow keys to adjust the knob’s resolution (0.10~15mA for ACW, 0.10~7.5mA for DCW).

Press FIELD key again to enter the next field “ramping time”. Use the knob to adjust the desired ramping time while using the arrow keys to adjust the knob’s resolution (0~999.9s).

Press FIELD key again to enter the next field “testing time”. Use the knob to adjust the desired testing time while using the arrow keys to adjust the knob’s resolution (0~999.9s).

Press FIELD key again to return to the first field “test mode” again.

Press EDIT/SAVE key to save all the parameters.

- **Continuous AC/DC withstanding voltage test (CAC/CDC)**

The CAC/CDC test is available only on step “0:0”. Like the traditional hipot tester, you can use the knob and arrow keys to adjust output voltage during the test.

All the parameters of CAC/CDC are the same as ACW/DCW, except the testing time. The testing of CAC/CDC is not limited.

- **Insulation Resistance test (IR)**

Press MENU key to enter status MENU then use the knob and Arrow keys to select a step.

Press EDIT/SAVE key to enter status EDIT. Now the cursor stays at the “test mode” field. Use the knob to select IR mode.

**Functionality of FIELD key:**

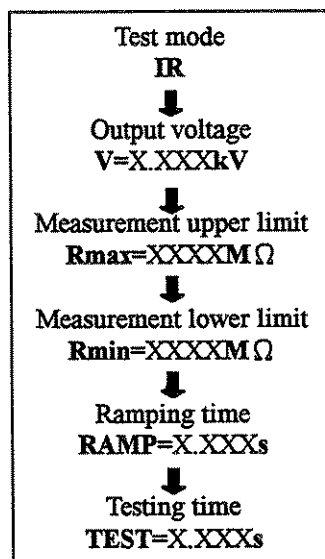

## Vitrek V50 Series – Electrical Safety Tester USER MANUAL

---

Press FIELD key to edit the next field “output voltage”. Use the knob to adjust the desired output voltage (500V/1000V).

Press FIELD key again to enter the next field “measurement upper limit”. Use the knob to adjust the desired upper limit of resistance while using the arrow keys to adjust the knob’s resolution (0~9999M $\Omega$ ). If no upper resistance limit is desired, enter 0 and the upper resistance limit will be ignored.

Press FIELD key again to enter the next field “measurement lower limit”. Use the knob to adjust the desired lower limit of resistance while using the arrow keys to adjust the knob’s resolution (0~9999M $\Omega$ ).

Press FIELD key again to enter the next field “ramping time”. Use the knob to adjust the desired ramping time while using the arrow keys to adjust the knob’s resolution (0~999.9s).

Press FIELD key again to enter the next field “testing time”. Use the knob to adjust the desired testing time while using the arrow keys to adjust the knob’s resolution

Press FIELD key again to return to the first field “test mode” again.

Press EDIT/SAVE key to save all the parameters.

- **Continuity Check (Cnt)**

Press MENU key to enter status MENU then use the knob and arrow keys to select a step.

Press EDIT/SAVE key to enter status EDIT. Now the cursor stays at the “test mode” field. Use the knob to select mode Cnt. The output current is fixed at 0.100A.

**Functionality of FIELD key:**

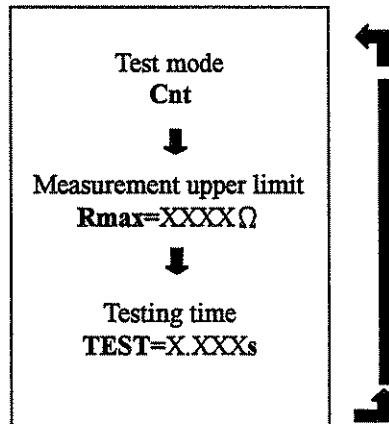

Press FIELD key to enter the next field “measurement upper limit”. Use the knob to adjust the desired upper limit of resistance while using the arrow keys to adjust the knob’s resolution (0~1.200).

Press FIELD key again to enter the next field “testing time”. Use the knob to adjust the desired testing time while using the arrow keys to adjust the knob’s resolution (0~999.9s).

Press FIELD key again to return to the first field “test mode” again.

Press EDIT/SAVE key to save all the parameters.

**Vitrek V50 Series – Electrical Safety Tester USER MANUAL**

**5-5 Remote Interface Operation**

For ease of automating the V50 Series unit when interfacing to a PC, we recommend the use the Vitrek QT50 test automation software and PC interface adaptor. The adaptor allows you to control the unit via a standard PC serial or parallel port, while the software allows for the development of test sequences and the storage of all test results for viewing or export to a database.

To prepare the unit for control via the remote interface press the UTILITY key and dial up the TEST CONTROL MODE using the knob. Press the SAVE/EDIT key to edit the field and use the knob to select MODE 3: PLC ENABLE, then press SAVE/EDIT to save the setting and press MENU to exit the utility mode. The unit is now configured for remote operation.

The remote interface provides two inputs (START and RESET) and three outputs (TESTING, PASS and FAIL). The I/O connector is a DB9 FM. Output contacts are rated at 400V/ 1.3 amps maximum.

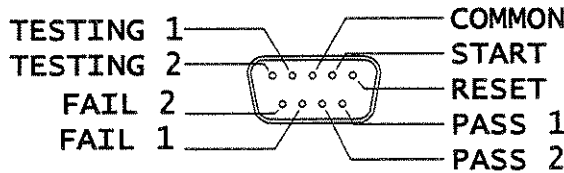

- RESET: Connecting "RESET"(pin 1) to "COMMON"(pin 3) will reset or interrupt this machine (the same functionality as the RESET button on the front panel).
- START: In status READY, connecting "TEST"(pin 2) to "COMMON"(pin 3) will start the test procedure (the same functionality as the START button in the front panel).
- TESTING1, TESTING 2: During the test, the "TESTING 1"(pin 4) and TESTING 2"(pin 5) will be shorted.
- PASS1, PASS2: If the result of the test is "pass", the "PASS 1" and "PASS 2"(pins 6 & 7) will be shorted.
- FAIL1, FAIL2: If the result of the test is "fail", the "FAIL 1 and "FAIL 2"(pins 8 & 9) will be shorted.

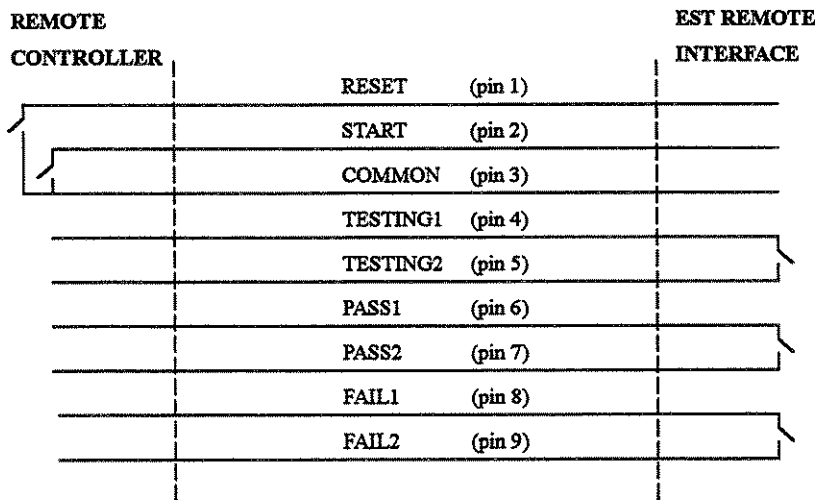

## **Vitrek V50 Series – Electrical Safety Tester USER MANUAL**

---

### **6. MAINTENANCE**

The following instructions should be used only by a qualified person in order to avoid electrical shock. Do not perform any service other than contained in the operation instructions unless you are qualified to do so.

#### **6-1. Fuse Rating and type**

If the fuse blows, the FUNCTION GENERATOR will not operate. Try to determine and correct the cause of the blown fuse, then replace the fuse with the correct rating and type shown as below:

Line voltage	Range	Fuse	Line voltage	Range	Fuse
100V	90-110V	T 4.0A	220V	198-242V	T 4.0A
120V	108-132V	250V	230V	207-250V	250V



**WARNING:** For continued fire protection, replace only with 250V fuse of the specified type and rating, and disconnect the power cord before proceeding fuse replacement.

#### **6-2. Cleaning**

To keep the instrument clean, wipe the case with a damp cloth and detergent. Do not use abrasives or solvents.

